

Highlights:

- High quality back electret condenser capsule with cardioid pickup pattern
- 35 cm flexing gooseneck microphone
- Integrated memory for voice-file storage & playback
- Level & status indication LED's
- Push to talk button

Product information:

The APM101 is a digital paging microphone for 1 zone which is equipped with a condenser element with cardioid characteristic, mounted on a 30 cm gooseneck. By means of a built-in compressor / limiter, the output level of the microphone signal is constantly maintained. The status of the reproduced signal is indicated on the front panel to ensure the speaker that the message is clear and audible in all situations. The console has a Push To Talk button.

Applications:

- Corporate
- Sporting facilities



System specifications:

Microphone	Type	Back electret condenser
	Gooseneck length	350 mm
Polar Pattern		Cardioid (unidirectional)
Frequency	Response (± 3 dB)	100 Hz - 20 kHz
Sensitivity (1W/1m)		-42 dB
Buttons		1 x programmable PTT (push-to-talk)
Indicators		3 Colours illuminated push button
		Level & status indication LED's
Internal storage		10 minutes audio or messages spread over max 30 files
Power	Consumption	4.8 W (max.)
	Supply	24 V DC (min. 16V DC)
Connectors		RJ45 (data + Power)
Max. cable length	Without external PSU	113 m
	With external PSU	300 m
Connection standard		TIA/EIA T568B

Product Features:

Dimensions		120 x 55 x 190 mm (W x H x D)
Weight		1.350 kg
Data protocol		RS-485
Audio protocol		Analogue
		Digital (configurable)
Required cabling	Analog	UTP CAT5E
	Digital	UTP CAT6
Colours		Grey metallic front panel
Construction		Steel
Accessories	Included	Windscreen (MWS05/B)
	Optional	ARJ03P junction box
		CP45ARJ RJ45 junction plate
		PSD24x external Power supply

Variants:

- APM101MK2 - MK2 version

Shipping & Ordering:

Packaging	Cardboard box
Shipping weight & volume	2.000 kg - 0.0012 Cbm

Architects' and Engineers' Specifications:

The digital paging microphone shall be a one zone system, allowing free selection and programming of zones and/or functions. It shall contain a gooseneck microphone with a length of 350 mm which is fitted with a back electret condenser element with cardioid polar pattern. A built-in compressor/limiter shall keep the output level of the microphone at a constant level. The front panel shall contain LED indicators whereby the level of the spoken message can be monitored, giving feedback to the speaker for a clear and intelligible spoken message. Another LED shall indicate whether the data bus is occupied by another con-sole which may be connected to the same data bus. The programmable function of the zone/function indication button shall include zone selection, push-to-talk, relay activation and voice file playback. In addition to these standard features, 'Multiple Ding-Dong' and 'Voice file playback' functionality shall be offered, allowing you to upload custom chime tunes for playback ahead of spoken voice announcements and record or upload messages for storage in the internal memory allowing playback triggering by button activation or at pre-defined moments. The audio output shall be configurable and compatible with both analogue and digital audio systems, allowing the paging micro-phone to be used in combination with various intelligent matrix systems as well as intelligent relay switch units enabling implementation to other sound / announcement systems. The connection of the paging system with the main unit shall be implemented using a single RJ45 connector which includes both data and power distribution. The used transmission medium for both audio and RS-485 communication shall be done over one single UTP CAT5E (for analogue audio transfer) or CAT6 (for digital audio transfer) cable. The system enclosure shall be solid constructed using steel materials with a front panel finished in a grey metallic colour. The base dimensions shall be 120 x 55 x 190 mm and the weight shall not exceed 1.35 Kg.

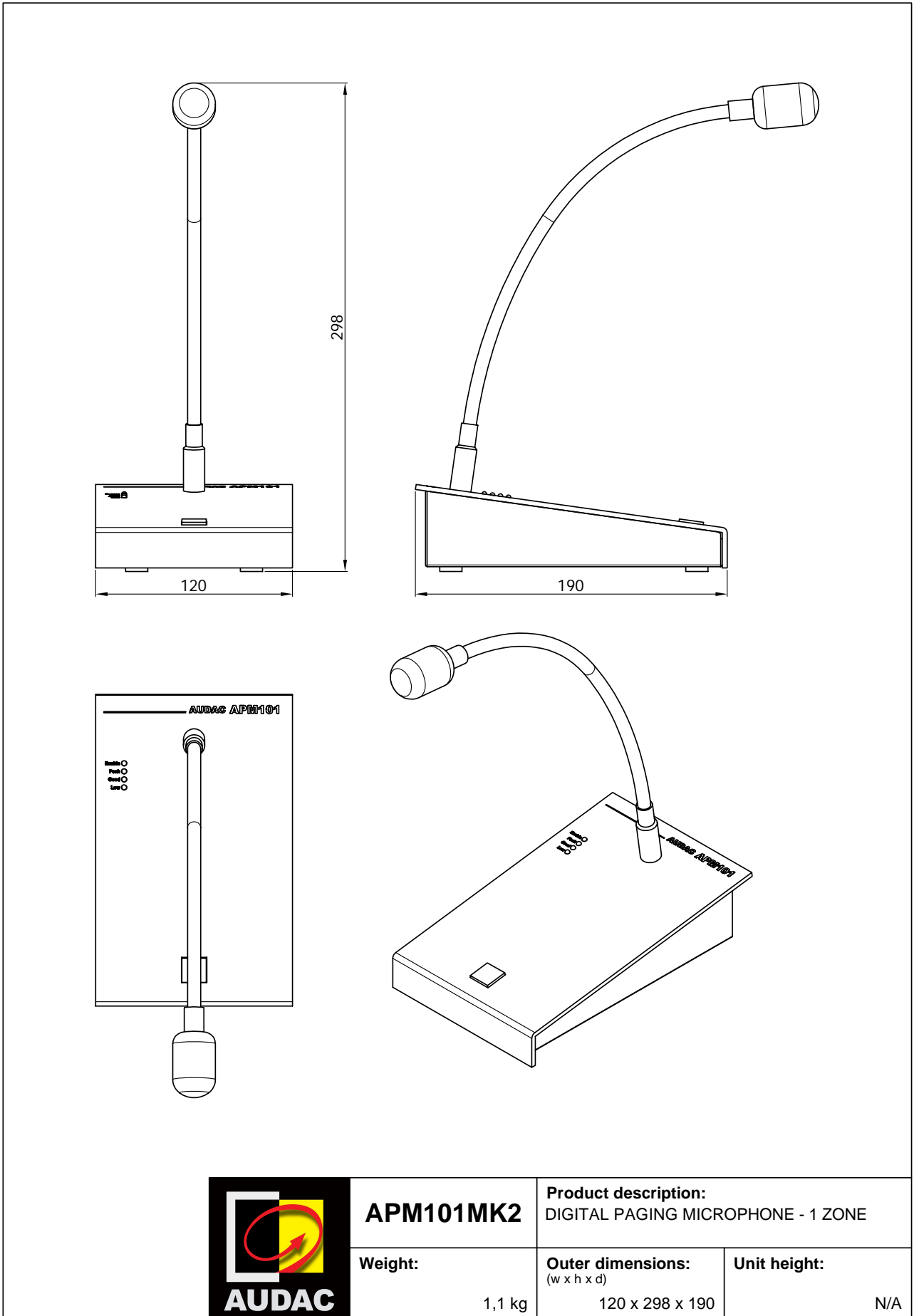

APM101MK2

Product description:
DIGITAL PAGING MICROPHONE - 1 ZONE

Weight:
1,1 kg

Outer dimensions:
(w x h x d)
120 x 298 x 190

Unit height:
N/A